



Installation Instructions

Application Fits

2014-2016 Toyota Highlander Including Hybrid
X7250

2" EcoHitch Stealth

5,000 lb. Weight Carrying/500 lb. Tongue Weight

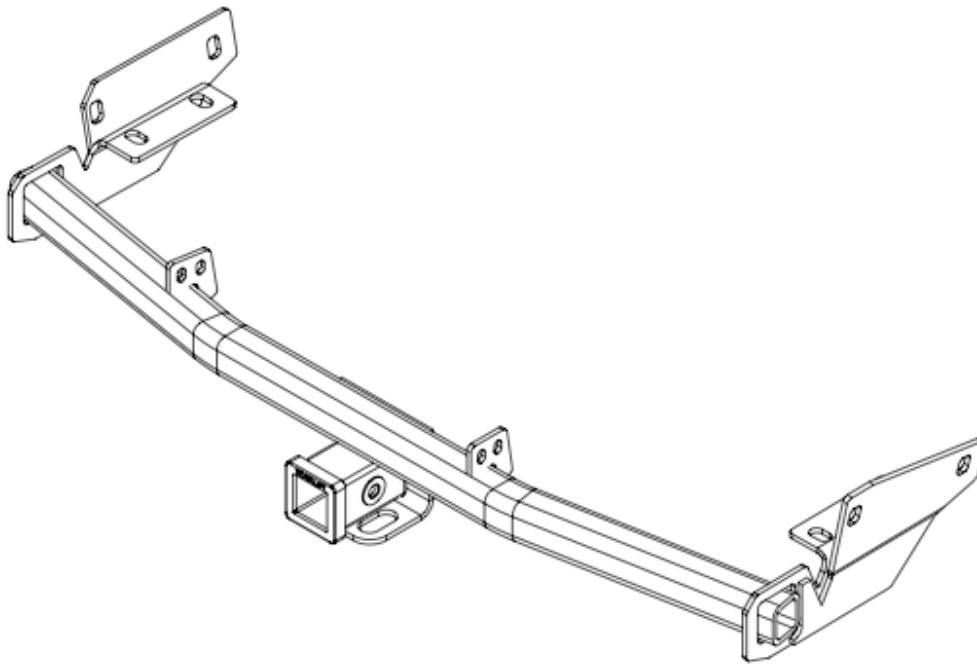

Torklift Central
315 Central Ave N
Kent, WA 98032
253-854-1832
www.torkliftcentral.com
support@tlcentral.com

Stay Connected



Bolt Kit Weight:783g +/-

Hardware Included

QTY Fastener

- 4 3/8"-16 Flange Nut
- 4 3/8"-16 x 1" Bolt
- 16 1/2" Flat Washer
- 8 1/2" Lock Washer
- 8 M12 - 1.25 x 40mm Bolt
- 1 Cross Tube Bracket Driver Side
- 1 Cross Tube Bracket Passenger Side

READ THESE INSTRUCTIONS THOROUGHLY AND ACCOUNT FOR ALL HARDWARE LISTED BEFORE BEGINNING INSTALLATION!

Step 1. Raise vehicle on suitable jack stands or hoist.

Step 2. Remove spare tire for installation.
See owners manual for spare tire removal.

Step 3. Locate flap near exhaust muffler outlet and trim on the dotted line as shown in Figure [1] using an air saw or utility knife. Discard flap.

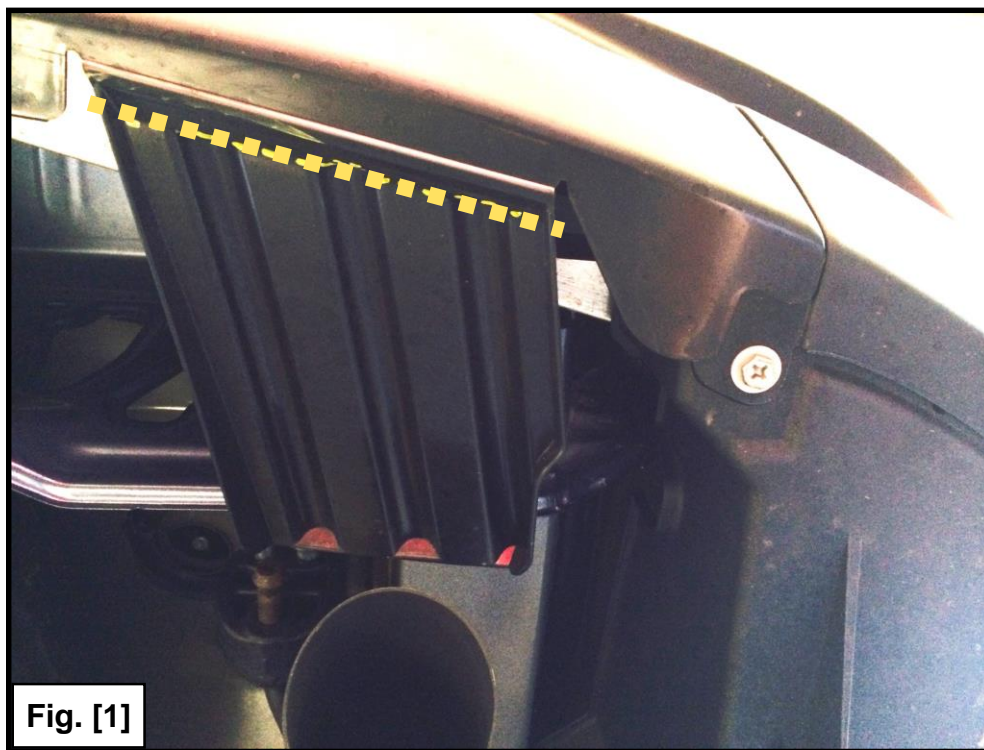
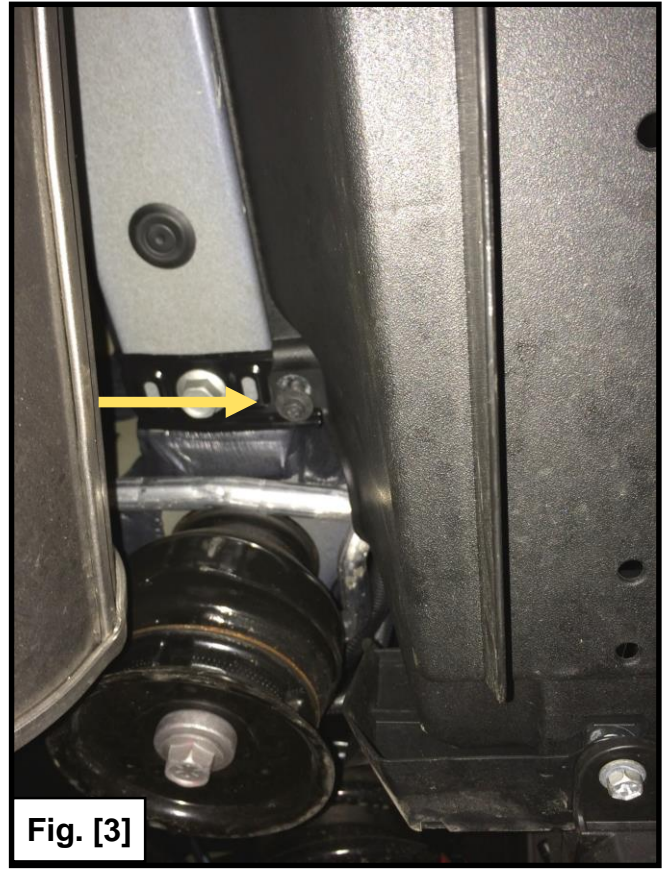
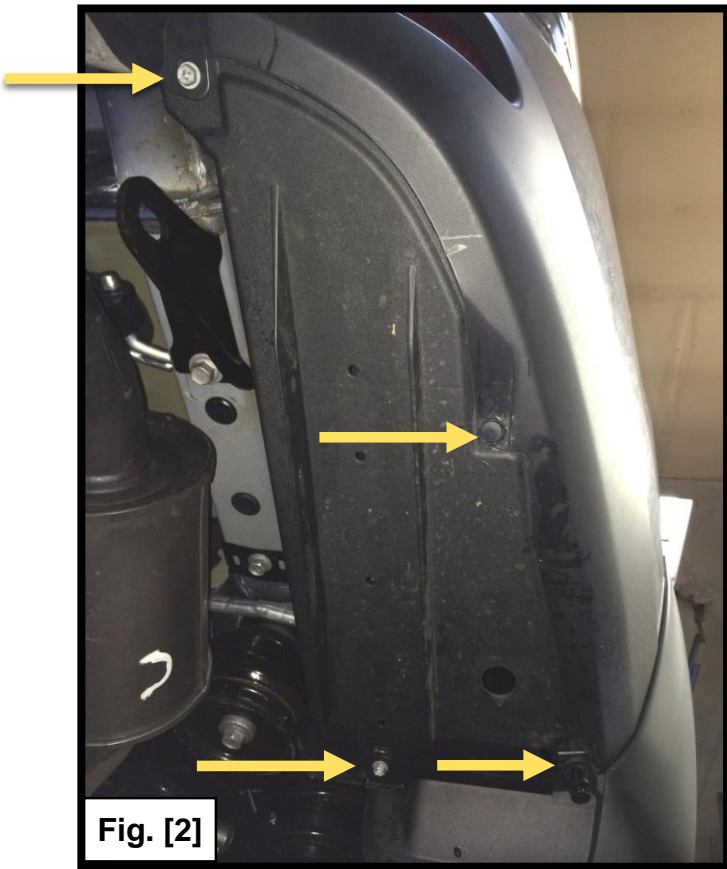
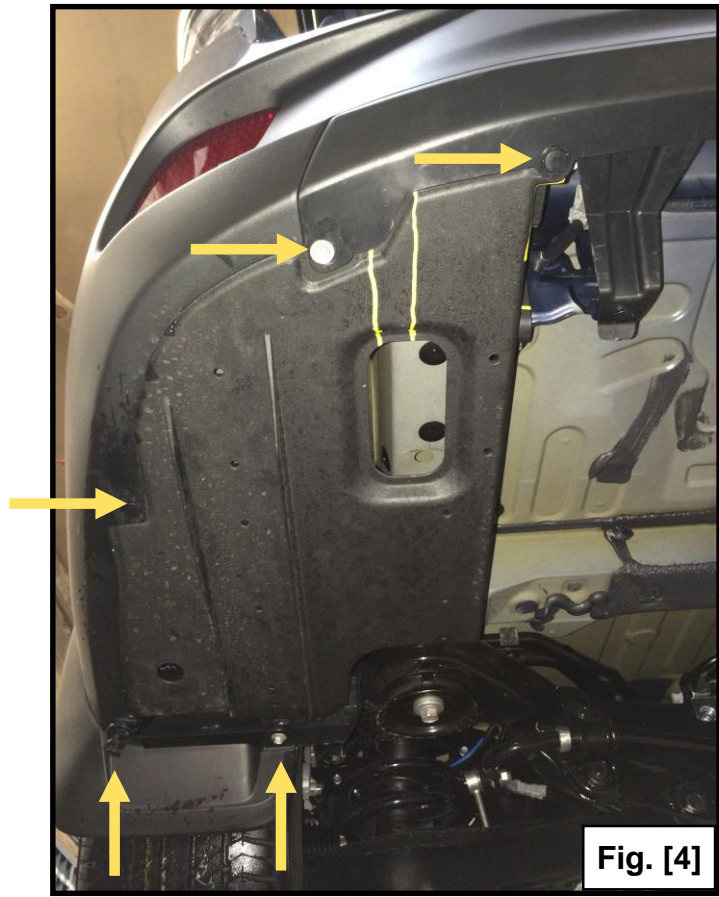

Fig. [1]

Step 4. Remove the passenger side panel as shown in Figure [2] & [3]. Remove screws and plastic clips noted with arrows. There is also a screw that is on the top of this panel underneath the vehicle.



Step 5. Remove the drivers side panel by removing screws and plastic clips shown with arrows in Figure [4].



Step 6. On the driver and passenger side you will notice (2) plastic bumper tabs attached to metal tabs. Remove the plastic clips connecting the tabs to the vehicle and cut the plastic tab (along yellow dotted line) to clear room for the hitch. It is not necessary that these tabs be reattached. Note: Pre 2016 models may not have the wider tab. See Figure [5].

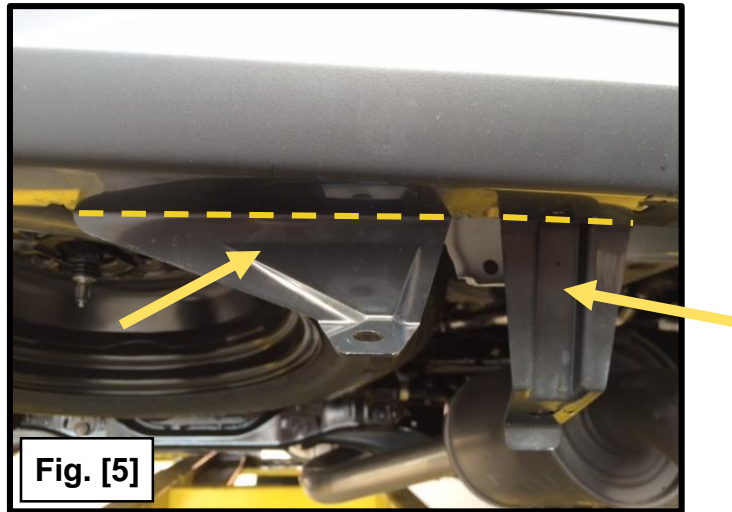

Step 7. Remove the factory tow hook and discard or return to customer.

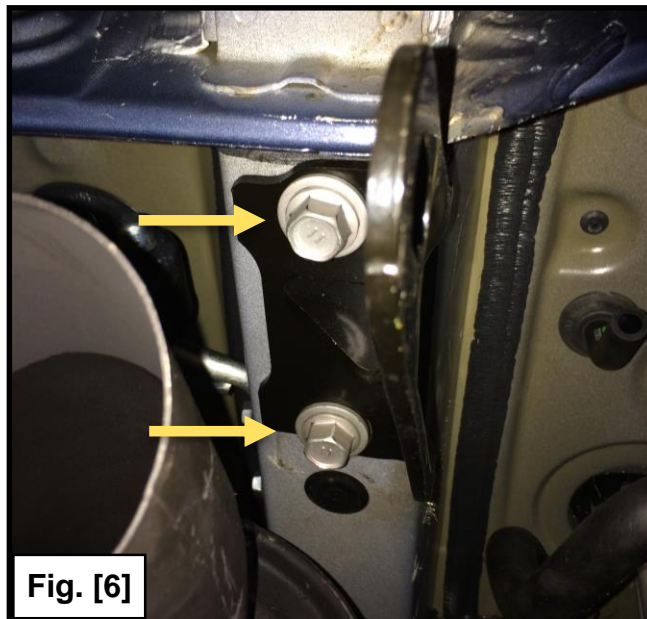

Step 8. Remove the screws holding the exhaust hanger in place. Support the exhaust with a stand or other prop to avoid damage. See Figure [7].

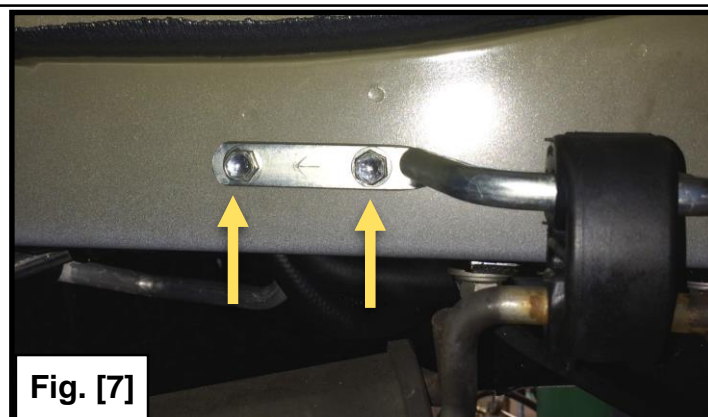

Step 9. Remove the (4) frame rail plugs located on the driver and passenger side to expose the weld nuts in the frame rails. Discard the plugs. See Figure [8].

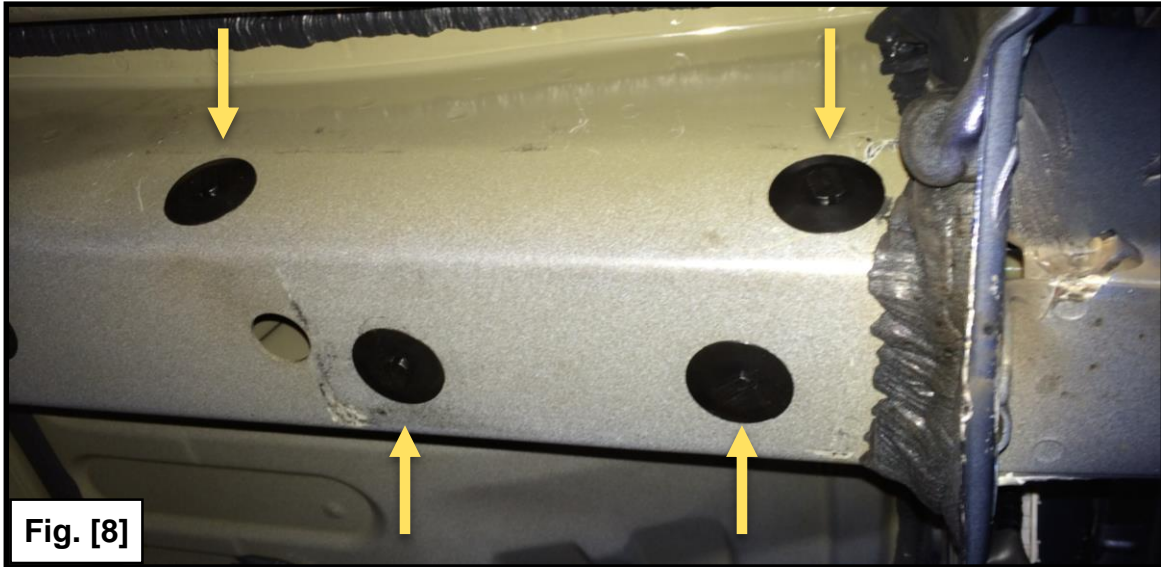

Step 10. Raise the hitch into position onto the frame, lining up the holes in the frame plates and the weld nuts in the frame rails. Once in position take (1) M12x1.25x40mm bolt, (1) 1/2" lock washer, and (2) 1/2" flat washers and thread into hitch and frame. Repeat on remaining holes and hand tighten. Torque all (8) bolts to 65 ft-lbs.

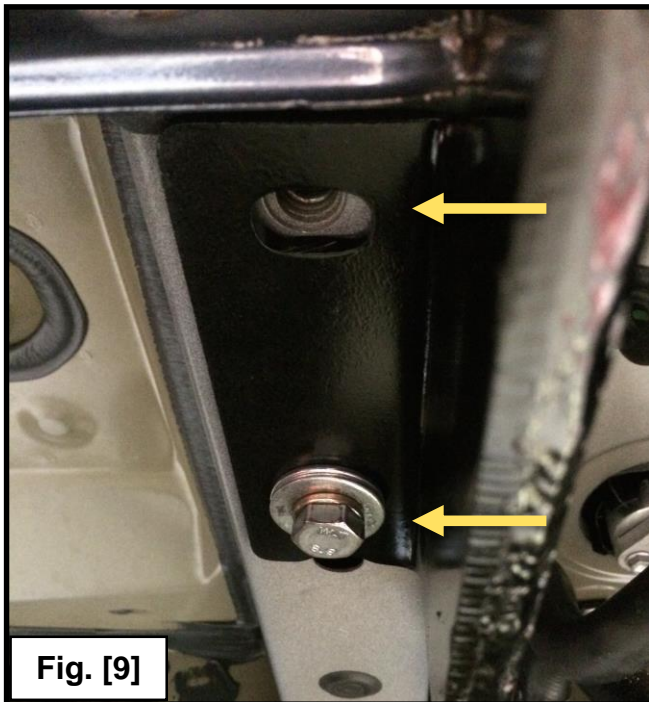

Step 11. Place the cross tube brackets onto the hitch with the bent tabs facing inward toward each other as shown in Figure [12] & [13].

Secure brackets with (1) 3/8"x1" bolt and (1) 3/8" flange nut and hand tighten. Repeat on remaining holes and torque to 31 ft-lbs.

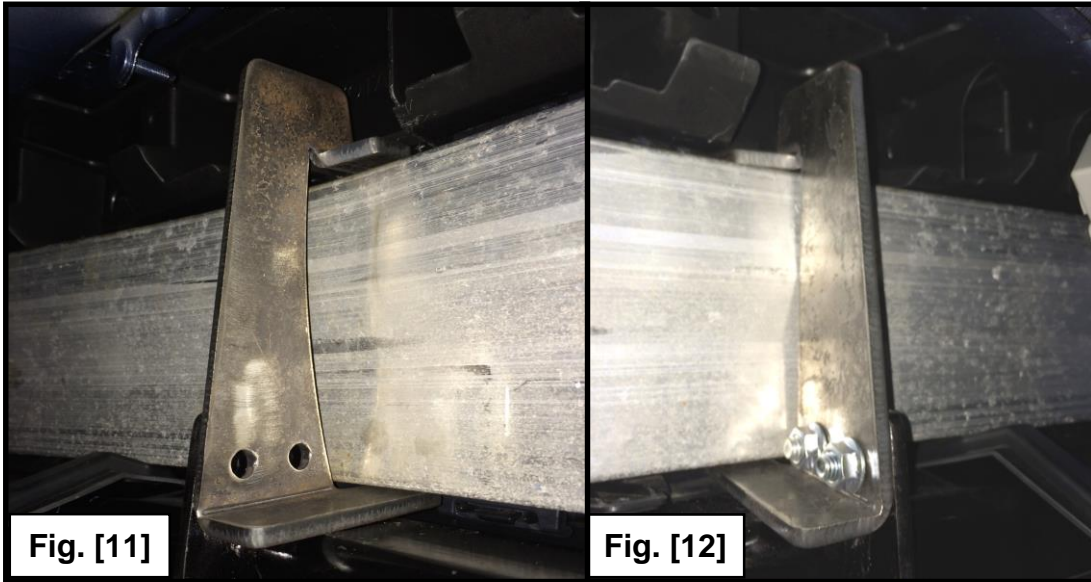

Step 12. Trim the driver side panel removed in Step 5 as shown in Figure [13]. Our installation shows the maximum amount of trimming required. In your installation you may be more comfortable trimming less plastic from the panels for a tighter fit.

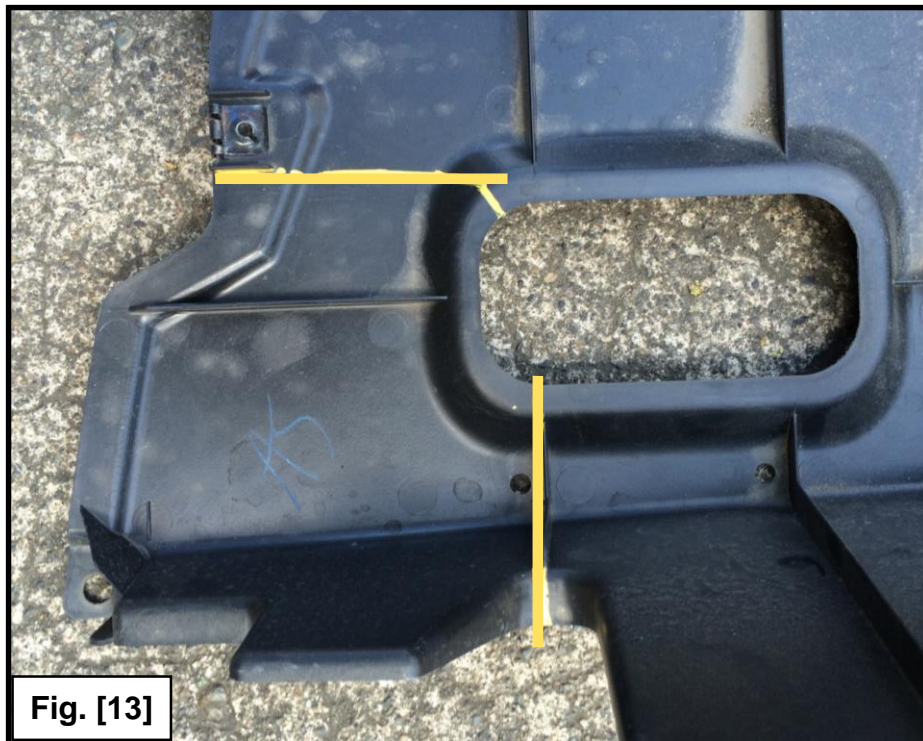

Step 13. Trim the passenger side panel removed in Step 4 as shown in Figure [14]. Our installation shows the maximum amount of trimming required. In your installation you may be more comfortable trimming less plastic from the panels for a tighter fit.



Fig. [14]

Step 14. Reattach plastic panels on driver and passenger side to the vehicle using existing fasteners.

Step 15. Re-install the spare tire following the owners manual instructions.

The hitch is designed with the spare tire in mind so that the orientation of the tire is unchanged.

Congratulations on the completed installation of the Toyota Highlander Hidden EcoHitch! It is designed with a lifetime warranty for a lifetime of enjoyment. If you have any questions or suggestions, please contact our tech support at support@tlcentral.com or by phone at 253 854-1832.



WARRANTY/DISCLAIMER INFORMATION

Torklift Central requires proof of purchase for warranty claim registration, with pictures of any defective product before issuing a replacement. Torklift will not accept claims on any product without proof of purchase, which can be faxed, scanned, emailed or mailed to the information provided below. Torklift Central warrants its hitches, custom hitch receivers and accessories (excluding electrical wire harnesses which carry a warranty from their specified manufacturer) from date of purchase against defects in material and workmanship under normal use and service for the ownership life of the original consumer purchaser. Torklift Central will replace free of charge any part that proves defective in material or workmanship when presented to Torklift Central, transportation charges prepaid by purchaser, at the address below. **This warranty is limited to defective parts replacement only. Labor charges and/or damage incurred in installation or replacement, as well as incidental and consequential damages connected therewith are excluded.** This warranty does not include normal wear and tear or the finish and paint. Rusting, cracking or peeling of the finish is also excluded. Some states do not allow the exclusion or limitation of incidental or consequential damages, so the above limitation or exclusion may not apply to you. Any damage to Torklift Central products as a result of misuse, abuse, neglect, accident, improper installation or any use violative of instructions furnished by Torklift Central will void the warranty. This warranty gives you specific legal rights and you may also have rights, which vary from state to state. With warranty service, you may be able to go to a small claims court, a state court or a federal district court.

Although Torklift Central trailer hitches are both tested and rated for towing within the specific capacity label found on each trailer hitch. Torklift Central assumes no liability for vehicle manufacturers warranty due to the use of a Torklift Central trailer hitch being used for towing behind any vehicle or using the trailer hitch in a manner that it was not designed for. Although this specific trailer hitch has a load rating, which includes trailer tongue weight, and a trailer weight carrying capacity, Torklift Central is not responsible for the voiding of any warranty on any vehicle due to factory towing limitations. All vehicle warranties are the sole property and responsibility of the owner of the vehicle that the Torklift Central trailer hitch is installed upon. Torklift Central does not endorse towing behind any vehicle if the vehicles manufacturer states that towing is not recommended. Check your vehicle's owner's manual for the proper tow rating of your vehicle.

ADDRESS: 315 Central Ave N. Kent, WA 98032

WARNING Your vehicle may have a lower tow rating than this trailer hitch. If your vehicle's tow rating is less than the rated towing capacity on your Torklift Central trailer hitch, your trailer hitch capacity is limited to your vehicle's factory rated towing capacity.

FOR EXAMPLE: the label on your Torklift Central trailer hitch states it's capacity is rated for 500 pounds tongue weight and 5,000 pounds towing weight. However your vehicle's factory rated towing capacity is limited to only 350 pounds tongue weight and 3,500 pounds towing weight. In this example your maximum towing capacity of your Torklift Central trailer hitch is limited to 350 pounds tongue weight and 3,500 pounds towing weight as stated by your vehicle's maximum factory tow rating.

DANGER Never exceed your vehicle's manufacturer's recommended towing capacity which may be a lower rating than this trailer hitch

Unsure of your tow rating? Download our towing app from the app store to find your vehicles tow